

# North Carolina Wood Ducks

Natural History and Management



*North Carolina  
Wildlife Resources  
Commission Division of  
Wildlife Management*

# North Carolina Wood Ducks

Natural History and Management



N.C. WILDLIFE RESOURCES COMMISSION

**B**y the late 1800s, wood duck populations were on the verge of extinction. Causes for decline included market hunting for meat and plumage, extremely long hunting seasons and a lack of protective laws. Habitat loss through swamp drainage, extensive timber cutting of bottomland hardwoods and the extirpation of the beaver over much of its range also played a major role in the near demise of the wood duck. With the passage, however, of the Migratory Bird Treaty Act of 1918, authority to regulate hunting seasons was given to the governments of the United States and Canada. An immediate closed season for wood ducks that lasted until 1941 and regulated hunting thereafter has helped the wood duck rebound to become one of the most important game ducks today.

### CLASSIFICATION

The scientific name of the wood duck is *Aix sponsa*. It is a member of the Class—Aves, Order—Anseriformes, Family—Anatidae. It is a member of the Tribe Cairinini, being its only member native to North America. The wood duck is most closely related to the brilliantly colored mandarin duck of the Orient. The wood duck is similar to other dabbling ducks (such as the mallard and pintail) that can spring or jump directly from the water when taking flight. The wood duck, “woodie” for short, is known by several other common names including summer duck and Carolina duck.

### DESCRIPTION

The wood duck is widely considered as the most beautiful duck in North America. The drake (male) is characterized by its iridescent green and purple crested head, prominent white chin bars, burgundy chest, and bronze sides with fine black vermiculations (wavy markings). The hen (female) is also attractively marked when compared to other dabbling duck hens and is distinguished by a prominent white eye ring. When in eclipse or nonbreeding plumage, both males and females become more mottled brown and generally less descript. Juveniles are similar in appearance to adults in eclipse plumage.

Weighing about 1.5 pounds and approximately 20 inches in length, wood ducks are of average size when compared to other dabbling ducks. Female woodies, distinctly recognized by their loud “wee-e-e-k, wee-e-e-k” call, are aptly nicknamed “squealers.” The male call is a soft “twee, twee” and is rarely heard.

The breeding range includes the eastern half of the United States and the states along the Pacific coast as well as the southern portions of several Canadian provinces (Figure 1). Isolated populations have been introduced in several Rocky Mountain and Plains states. The wood duck is the most abundant duck species nesting east of the Mississippi River. The wintering range of wood ducks occurs primarily in the southeast and Gulf Coast states. Wood ducks breeding in the western area winter predominantly in California.

Wood ducks breed in all physiographic regions and counties in North Carolina. In winter they may be found throughout the state; however, the largest numbers occur in the Piedmont and Coastal regions.

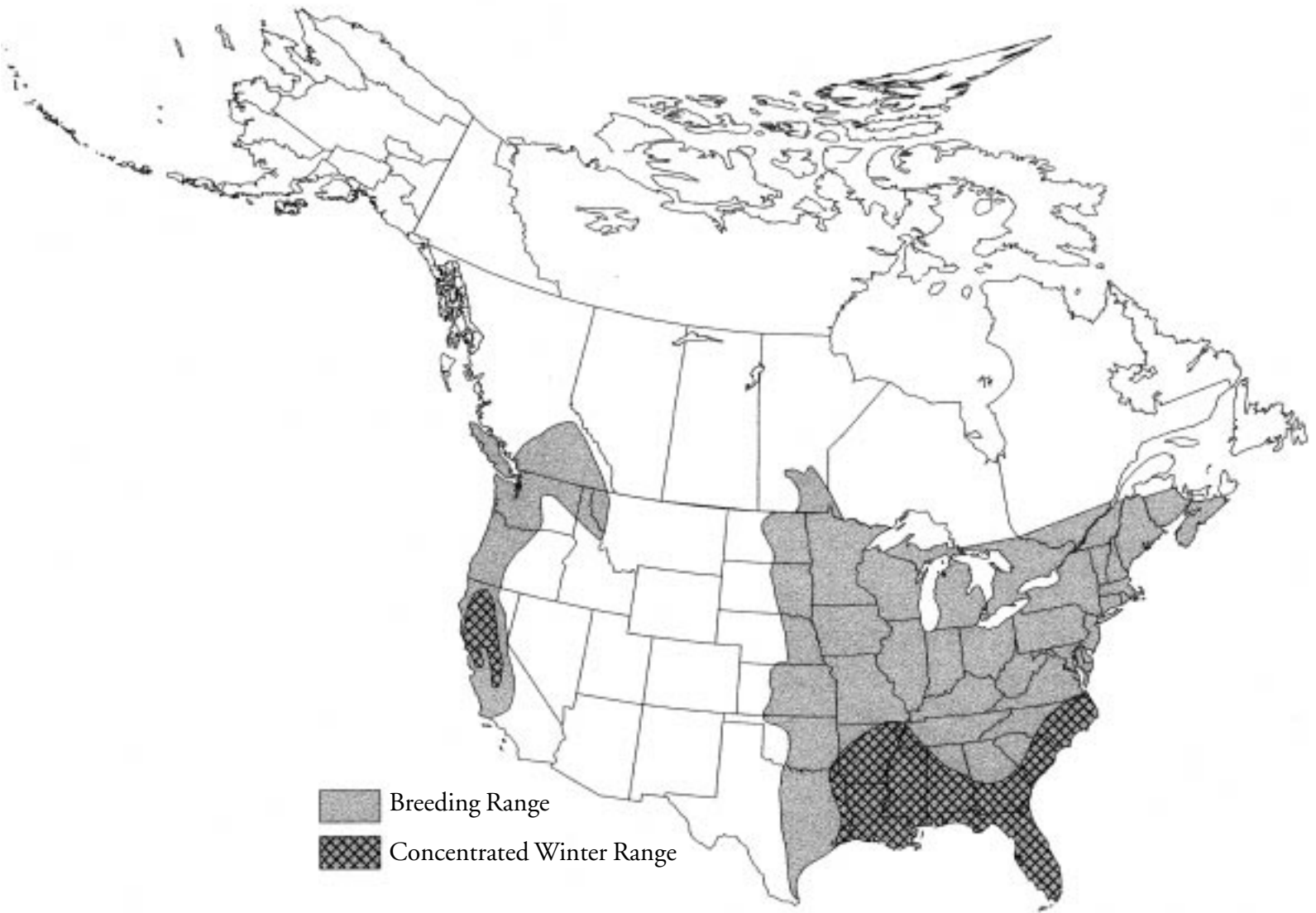

**FIGURE 1**  
*Breeding range and concentrated winter range of the wood duck*

Wood ducks require forested wetland habitat for food and cover. In North Carolina this type of area may be associated with beaver ponds, swamps, mountain bogs, farm ponds, small streams, managed impoundments, and backwater sloughs and oxbows of large rivers and reservoirs. Marshes are less used due primarily to a lack of nesting cavities. Beaver ponds provide excellent nesting, feeding and brood-rearing areas for wood ducks. In spite of losses of bottomland hardwoods through timber cutting, wood duck numbers in North Carolina have remained stable or increased in part as a result of the range expansion of beavers.

EUGENE HESTER



*Beaver ponds are found throughout North Carolina and provide many of the wood duck's habitat requirements.*

### NESTING SITES

Wood ducks are cavity-nesting birds: They depend on large, mature trees for the availability of natural cavities. Wood ducks will also readily use artificial nest boxes as nesting sites. Preferred natural cavities have an entrance size of approximately 4 inches x 3 inches and a depth of 24 inches. Cavities must have well-drained floors. Wood ducks will nest over water or land and normally select sites from 6 to 55 feet high.

Many different tree species provide natural cavities. Several important species that provide nesting cavities in North Carolina as well as other southern states include the following: sycamore, American beech, elm, red maple, tupelo, sweet gum and bald cypress. Studies have reported a range of 0.3 to 14.0 suitable nesting cavities per acre in forest stands, and the density of natural cavities is generally lower in the southern states. Thus, the lack of suitable nesting cavities is a primary factor in limiting wood duck populations over much of its range.



N.C. WILDLIFE RESOURCES COMMISSION

*Mature hardwood trees provide cavities needed by wood ducks for nesting. Preferred cavities have a small entrance hole and a depth of 15 to 25 inches.*

#### **WATER**

Wood ducks are attracted to areas of shallow water for feeding. Water depths of 3 inches to 3 feet are optimal, although deeper water is sometimes necessary to provide openings free of tree and shrub cover. Preferred brood rearing areas have still or slow-moving water and are sheltered from the wind. Water should be present two to three weeks prior to nesting through the brood-rearing period (February - July). Nest sites, however, do not have to be located near water. Some wood ducks will commonly nest 0.5 miles or more from water. Broods, however, encounter a higher rate of predation when attempting to reach water after hatching.

#### **COVER**

Adequate cover is an important ingredient in determining quality wood duck habitat. Because of their secretive nature, cover is important in allowing wood ducks to feel secure in their surroundings. Vegetation overhanging the edges of streams, ponds and lakes is vital in providing concealment and escape cover for wood ducks and young broods. Ratios of cover to open water have been suggested as 50:50 for breeding habitat and 75:25 for brood-rearing areas. Vegetation providing good cover includes cypress, tupelo, alder, willow, buttonbush, water primrose, arrowhead, spatterdock and smartweed.

#### **FOOD**

Wood ducks are opportunistic feeders that consume a wide variety of food items (Table 1). Wood ducks feed on seeds, fruits and tubers of many trees, shrubs, and aquatic forbs and grasses. Acorns, however, are the preferred food, especially during the fall and winter. Their varied diet and ability to exploit locally abundant food sources are primary reasons for the wood duck's ability to adapt to many different habitat types.

Throughout the year, adult males consume approximately 65 percent plant foods and 35 percent animal foods (such as aquatic and terrestrial insects, snails and crayfish). Females have similar food habits to males in the fall, but their intake of animal foods increases to nearly 80 percent in the spring due to their high protein demand during the egg-laying period. Protein demands for young ducklings are also very high, as they will consume up to 85 percent animal foods to about 6 weeks of age.

Trees (fruits & seeds)	Forbs and Grasses (seeds & plant material)
Oak Hornbeam Wild grape Bald cypress Tupelo gum Hazelnut Beech Maple Elm	Arrowhead – duck potato Burreed Watermeal Duckweed Pondweeds Sedges Smartweeds Arrow arum – wampee corn Waste corn Pickerelweed Water primrose Barnyard grass Spatterdock

**TABLE 1**

*Common plant food items for wood ducks in North Carolina.*



*Preferred brood rearing areas are characterized by still or slow-moving water and stands of emergent vegetation or vegetation overhanging the waters edge.*

N.C. WILDLIFE RESOURCES COMMISSION

## NESTING

Pair formation begins as early as late October and continues through the fall and winter. Pair formations are usually complete by late February. Nesting begins as both drake and hen begin to search for nest sites. Early in the morning, the drake follows the hen as she flies to various cavities, inspecting each to determine if it is acceptable. Unless the hen returns to the cavity occupied the previous year, she may search for several days before finding a suitable one. Wood ducks will renest if original nests are destroyed by predators, and some may successfully hatch two broods in one nesting season.

The eggs are dull white and are normally laid at the rate of one per day. The first eggs are covered by litter found in the nest cavity or nest box. After laying the sixth or seventh egg, the hen adds small amounts of down with larger amounts added when her clutch nears completion. Normal clutch size ranges from 10 to 15 eggs and averages around 12 eggs. Dump nests, usually with greater than 15 eggs, occur when more than one female contributes eggs to a single nest. A dump nest observed in eastern North Carolina contained 51 eggs. Dump nests are thought to occur when nesting density is high, sometimes a problem when many nest boxes are placed too close together.

N.C. WILDLIFE RESOURCES COMMISSION

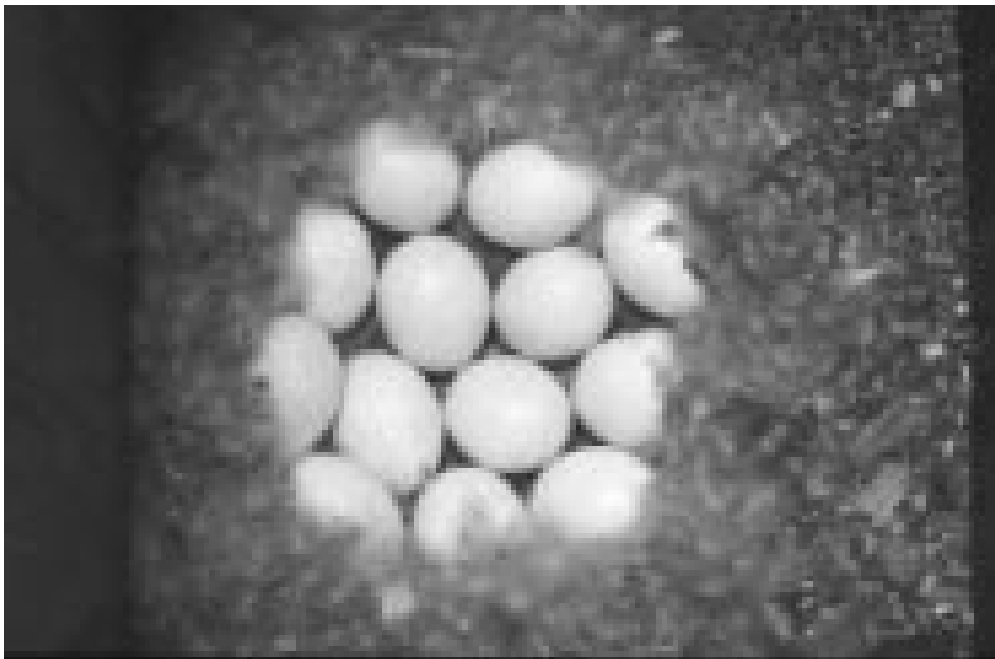

*The normal clutch size for wood ducks ranges from 10 to 15 eggs. Large amounts of down are added as the clutch nears completion.*

Incubation begins when the last egg is laid and ranges from 28 to 37 days with an average of 30 days. During this period, the hen generally leaves the nest twice each day: once in the morning and once late in the afternoon for about an hour each time. To keep the eggs warm, she will cover them with a layer of down before leaving. She will spend less time away during cold weather and late in incubation. The male plays no part in incubation.

The hatching process starts at about 28 days when the young begin pipping and calling from within their shells. After about two days, most of the young have emerged. Wood ducks are precocial and thus are able to leave the nest immediately. Depending upon when the clutch is finished hatching, the hen and brood will leave the nest the next day or the day after. When leaving the nest, the hen positions herself under the cavity or nest box and softly calls to the young. The young peep back, climb from the nest and then fall to the ground or water. Even when falling from long distances, the young land uninjured and immediately follow the hen to the nearest cover.

### **BROOD REARING**

Although they are largely independent and able to feed on their own, the young will continue to be brooded several weeks after leaving the nest. Ducklings will remain close to their mother for the first three or four weeks. The hen provides a valuable service by watching for and alerting her young to nearby predators. Even so, predation during this period is quite high. Nearly 50 percent of ducklings are lost between the time they leave the nest and the flight stage. Family bonds are broken when the young reach flight stage at about 8 to 10 weeks of age.

### **MOLTING**

During May through June, shortly after the breeding period, males begin to congregate and spend the night in communal roosts. At this time they begin a body molt during which they lose their bright breeding plumage. The resulting nonbreeding or basic plumage is drab and dull-colored. Males lose their wing feathers two to three weeks later and become flightless and very secretive at that time. They regain their flight feathers in about three weeks. Males generally regain their bright fall plumage in mid- to late September. Molting into the basic plumage begins in late winter for females. It is delayed, however, until the completion of brood-rearing duties, and then follows the same molting process as males. The timing of molts in females is less predictable due to variations in the dates of early nesting, reneating and second clutches.

### **MIGRATION**

Due in part to their large breeding range, which includes the South, wood ducks do not have as well-defined migratory pathways as other duck species. In late summer, before regular migration, some wood ducks (especially males and immature females) disperse in all compass directions from favored feeding and resting areas. Dispersal is not fully understood, but these movements are completed quickly and vary in length.

Autumn migration for North Carolina wood ducks begins in early fall, but total numbers of wood ducks in the state remain stable or increase due to the influx of northern birds. The northern

migrants begin to arrive in early to mid-October. Wood duck numbers generally peak in November and are at their lowest in January. Most wood ducks have left North Carolina's mountain counties by late fall, whereas coastal wood ducks may not migrate at all or only make short movements within the state.

### **PREDATION**

The wood duck has many natural predators including raccoons, mink, hawks, owls, snapping turtles and snakes. The raccoon is considered the most important predator throughout the wood duck range. Raccoons are extremely efficient in searching for wood duck nests and will consume unhatched eggs and kill nesting females when encountered. Snakes are also important predators during nesting and are known for wiping out entire clutches of eggs. The black rat snake is the only snake in North Carolina that preys substantially on wood duck eggs.

Predation by hawks and owls increases once ducklings leave the nest and become more vulnerable, especially when traveling considerable distances over land. The starling, introduced to the United States from Europe in 1890, is troublesome in that it competes for nesting cavities. Starlings are more aggressive and will force nesting wood ducks out of their cavity or nest box.



N.C. WILDLIFE RESOURCES COMMISSION

## POPULATION MANAGEMENT/MONITORING

### BANDING

To make better-informed decisions in setting waterfowl season lengths and bag limits, wildlife biologists and managers need to have an understanding of each species' population characteristics. Each year, biologists put leg-bands on thousands of wood ducks to help monitor this valuable resource. Most bandings occur during July through September when more information can be gained for local breeding populations than at other times of the year. From 1970 to 2000, 37,041 wood ducks have been banded in North Carolina by the N.C. Wildlife Resources Commission and the U.S. Fish and Wildlife Service.

Direct recoveries (those that occur the first hunting season after banding) of wood ducks banded in North Carolina have been recorded in 25 states and one Canadian province (Figure 2). Recoveries as far away as Maine and Ontario indicate that wood ducks disperse great distances from breeding areas in North Carolina. Most wood ducks, however, make only short migrational movements: Most recoveries occur within the state and slightly farther south in South Carolina and Georgia. Band recoveries indicate that a large percentage of birds banded in the Coastal and Piedmont regions are recovered in South Carolina, whereas a larger percentage of wood ducks banded in the Mountain region are recovered in Alabama, Mississippi and Louisiana.

Research indicates that about 48 percent of adult female and 60 percent of adult male wood ducks banded in the Atlantic Flyway survive to the following year. This estimate varies from year to year, and a precise estimate in some years is hampered by inadequate numbers of bandings.



MELISSA MCGAW

*Banding is an important tool that managers use to estimate survival rates and migration movements.*



**FIGURE 2**  
*Number of direct recoveries of wood ducks banded in North Carolina from 1970-2000*

**OTHER MONITORING TECHNIQUES**

Techniques currently employed in monitoring many duck species such as mallards, teals, pintails and canvasbacks are not useful in monitoring wood duck populations. Estimates of breeding population size and productivity for these species are measured through counts from aircraft over the prairie breeding grounds and on wintering areas. These flights provide little or no information on population size and productivity for wood ducks because of the difficulty in observing them in their densely wooded habitat. Indirect estimates of annual production are obtained through the examination of waterfowl wings collected by the U.S. Fish and Wildlife Service from hunters. At this time, techniques used to directly estimate population size and productivity on an annual basis across the species range have not been developed.



*Wood ducks may be captured by several methods, including rocket nets and wire swim-in traps.*

**BEAVER POND MANAGEMENT**

In many instances, water-level control provides the best technique for enhancing beaver ponds for wood ducks. An alternating cycle of draining and reflooding allows for the natural establishment of waterfowl food plants while reducing the risk of killing the newly flooded trees. Drainage of beaver ponds can be best accomplished by installing a drain. The Clemson Beaver Pond leveler is one such drain that has proven to drain ponds effectively while minimizing the probability that current flow can be detected by beavers. (See Figures 3 and 4.)

**INSTRUCTIONS FOR POND LEVELER INSTALLATION (Figure 3):**

1. Break the dam at the existing channel in the form of a narrow, deep "V".
2. Wait for the waterflow through the dam to lessen before beginning installation.
3. Make sure that the upstream end (intake side) is completely covered by water even when the pond is at a minimum depth. Approximately 20 feet of pipe should extend beyond the downstream side of the beaver dam. Various lengths of standpipe fitted to the PVC elbow on the outflow end will allow one to raise or lower the pond to various depths.
4. Once the leveler is installed, the beavers should repair the damage to the dam. The pond leveler however, will maintain the desired water level.

**POND LEVELER MATERIALS LIST**

QUANTITY	ITEM
1	10' section, 10" dia. PVC pipe (schedule 40)
1	PVC cap for 10" dia. PVC pipe (schedule 40)
1	10" x 8" PVC pipe reducer coupling (schedule 40)
4	86" sections, 3/4" dia. plastic roll pipe (water pipe), 160 psi grade
4	3/4" metal couplings for roll pipe
16	1/4" x 2" galvanized eyebolts
16	1/4" galvanized nuts
16	1/4" galvanized washers
16	16" sections, 8 ga. galvanized wire (medium hardness)
2	96" sections, 2" x 4" 12 1/2 ga. galvanized welded wire
2 lbs	Crab trap clamps (fasteners)

*The listed materials are required to assemble the intake device for the Clemson Beaver pond Leveler. The carrying pipe (flow pipe) may consist of 20 to 40 feet of 8" diameter PVC, Schedule 40 with coupling sleeves and elbows appropriate to the desired configuration.*

**FIGURE 3**

*Proper placement of Clemson Beaver Pond Leveler*

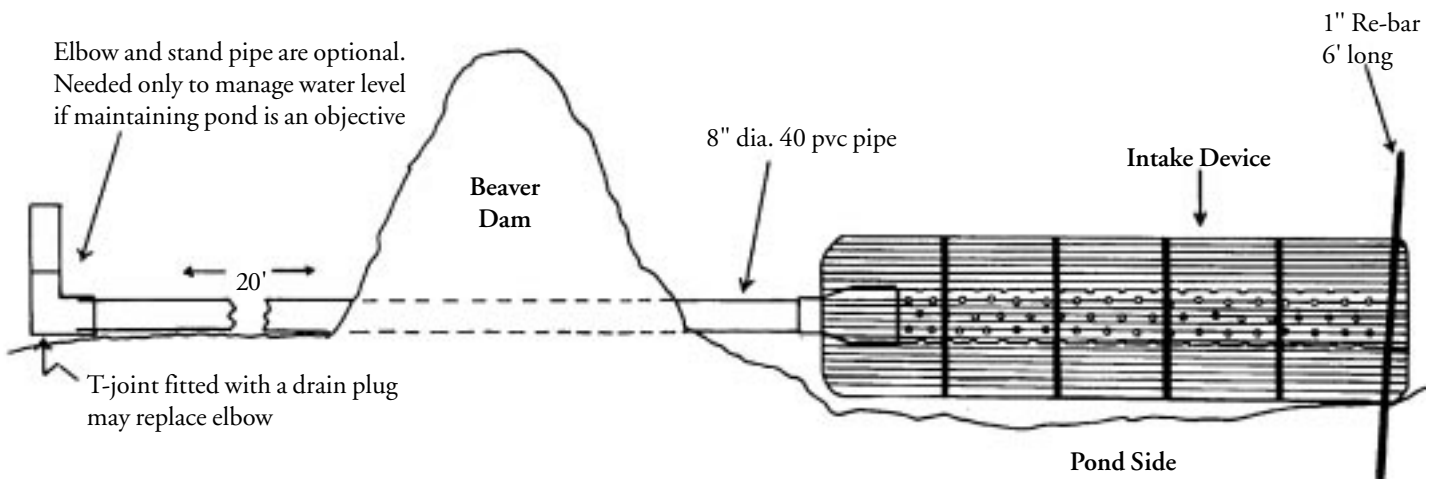

The original drain installation should be made during the fall or winter. Beavers are most likely to repair dams during the cool months. If installed during winter, the leveler should be fitted with a standpipe and then removed in summer to drain the pond. After the leveler is installed, it should be checked at least monthly and maintained as required to insure proper operation. Ponds that contain the beaver lodge are generally much more difficult to drain than surrounding ponds. Beavers will make an extra effort to repair dams and plug drains in these ponds. Any additional ponds surrounding the main lodge pond should be easier to manage.

New beaver ponds with live trees may be converted into green-tree reservoirs to attract waterfowl with minimal loss to timber production. Acorns are a preferred food for wood ducks, mallards and other species and oak trees can be maintained by draining the beaver pond during the growing season from March through November. Installing a standpipe just prior to the dormant season (December through February) allows the pond to relood, thereby providing resting and feeding areas for waterfowl. It is extremely important that water levels be managed to minimize risk to the hardwood overstory.

Old beaver ponds with dead trees and plenty of sunlight reaching the water can be developed into attractive feeding areas by draining the pond during the growing season. The pond can be allowed to revegetate naturally or planted to Japanese millet and then reflooded. When draining the beaver pond for any of the above mentioned operations, one-third to one-half of the water should be left to prevent beavers from relocating.

FIGURE 4

*Detailed diagram of intake portion of Clemson Beaver Pond Leveler*

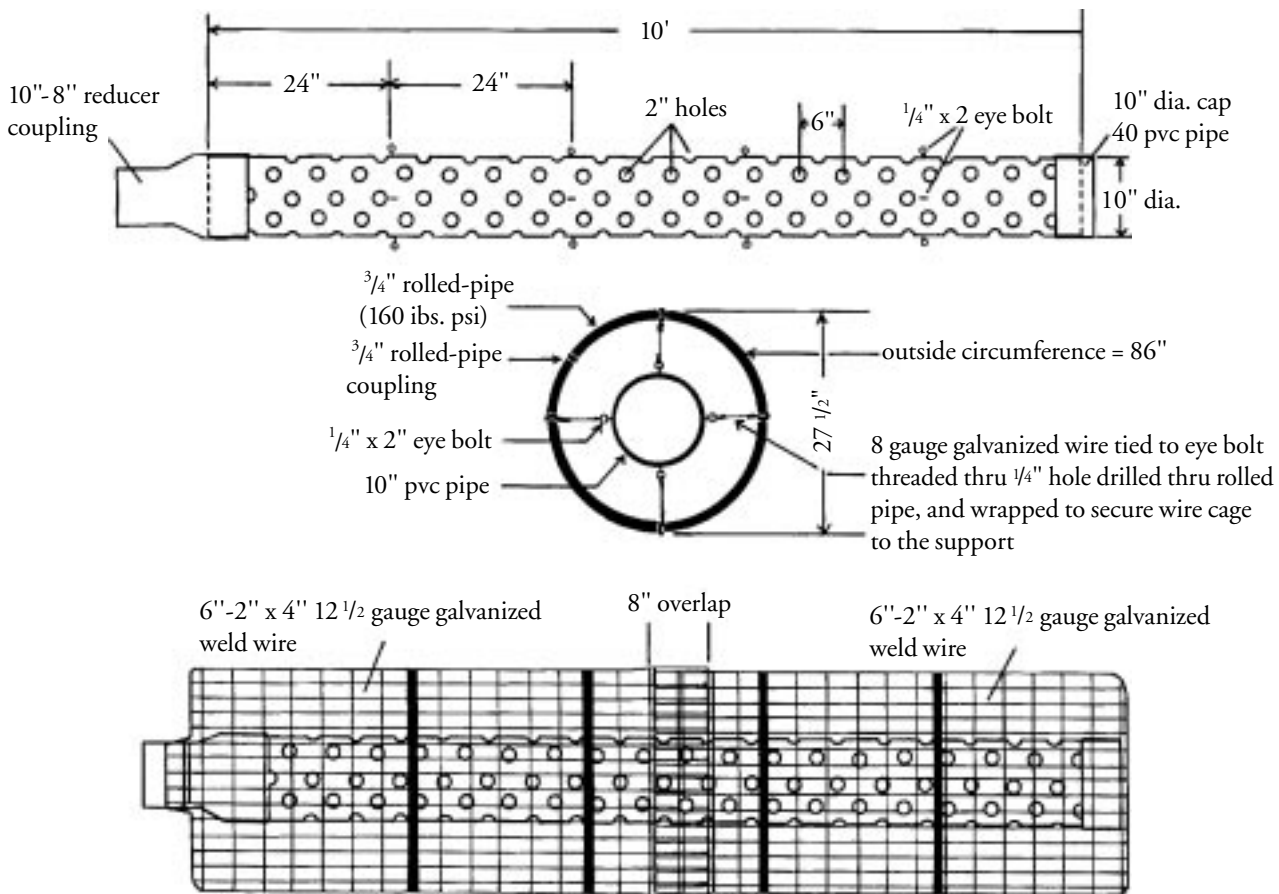



*Old beaver ponds with dead trees and abundant sunlight are excellent planting sites for Japanese millet*

KEN KNIGHT

#### MILLET PLANTING

1. Drain the pond just prior to planting.
2. Broadcast Japanese millet seed on the soil while it is still moist at the rate of 25 pounds per acre. Millet should be planted by July 15 in the mountains to as late as August 14 on the coast. Additional land preparation is not needed, and fertilizer should not be necessary for the first two years.
3. The leveler should be checked weekly to insure proper operation.
4. To flood the millet for waterfowl, install a standpipe to the leveler after the plants turn yellow and the seeds are mature. Seed maturity usually requires 45 to 50 days.
5. Drain the pond each summer (July) to allow the millet seed to germinate and grow. The original seeding may provide enough seed for re-establishment of millet for two to three years before re-seeding becomes necessary.

### GREEN-TREE RESERVIORS

Green-tree reservoirs are artificially flooded areas of hardwood timber where acorn mast can be used as food for waterfowl. Green-tree reservoirs are constructed by installing a flashboard riser in a pre-existing dike or road that crosses or impounds a slough or other water body. The flashboard riser should replace the existing culverts or overflow pipes. The riser allows water to be released or impounded in incremental steps, up to a depth of 18".



N.C. WILDLIFE RESOURCES COMMISSION

*A flashboard riser allows for the impounding and releasing of water in incremental steps in green-tree reservoirs and other managed impoundments.*



N.C. WILDLIFE RESOURCES COMMISSION

*Green-tree reservoirs can provide important overwintering habitat for wood ducks and other migrating waterfowl if sites first meet approval of wetlands regulatory agencies.*

A potential site for a green-tree reservoir should include the following characteristics:

1. A well-stocked stand of mast-producing hardwoods, especially oaks.
2. Level topography enough to flood 10 acres or more.
3. Soil capable of holding water.
4. Water available to flood the area from December through February.

As with beaver pond management, it is extremely important that water levels be controlled to have minimal impacts on the health and vitality of the hardwood stand. Prolonged flooding will first reduce mast production and eventually will kill the trees. Water should be drained during the growing season (March through November) and flooded during the dormant season (December through February). Every third year the reservoir should be completely drained for the entire year to prevent timber loss. Draining every other year may be warranted in some areas if trees become stressed. More harm may be done to habitat for wood ducks and other bottomland hardwood wildlife species if water levels are not controlled and trees are allowed to die.

Environmental laws prohibit placing of fill in wetlands during the construction of green-tree reservoirs. The U.S. Army Corps of Engineers must be contacted to determine if any permits are required before construction. In addition, district wildlife biologists can give advice and suggestions for site selection and advantages and disadvantages when considering building green-tree reservoirs.

A shortage of natural cavities is often a factor that limits wood duck populations. Properly installed and maintained, artificial nest boxes are an effective way to increase local populations of wood ducks.

### CONSTRUCTION

There are many types and designs of wood duck boxes, both homemade and commercially available. The photograph below and the plans on pages 18 and 19 depict a traditional design for a wood duck box that can be constructed with basic tools and materials. Whether you chose to use this design or another, several guidelines are recommended.

1. Lumber should be rough-cut, preferably cypress or cedar if available. If cypress or cedar is unavailable, lumber should be treated with a preservative to extend the life of the box. If smooth lumber is used, a 4-inch wide strip of 1/4-inch mesh hardware cloth must be tacked to the inside front of the box to help ducklings leave the box.
2. A side-door entrance is much preferred over a removable top. Older style boxes with removable tops make annual maintenance much more difficult.
3. Consider using screws instead of nails when fastening the box together. If a portion of the box becomes cracked or rots, screws can be removed and the old section replaced.
4. Although many plans call for 12-inch wide lumber, we have found that wood ducks will readily use boxes constructed of 10-inch wide boards.

### PREDATOR GUARDS

Boxes should not be installed without adequate predator guards. The cone-type predator guard shown in the photograph below is recommended because it has proven to be the most effective guard. Predator guards should be constructed from 26-gauge galvanized sheet metal. Predator guards can be attached to wooden posts with 1-inch roofing nails or to smooth pipe with screws and a hose clamp. Smooth pipe without a guard will not provide adequate protection from predators.

The likelihood of predation on eggs and nesting females using nest boxes increases if the boxes are placed close together and are not predator-proofed. If able to successfully enter a nest box once,

raccoons and snakes will continue to search all other nest boxes within the area for an easy meal.



N.C. WILDLIFE RESOURCES COMMISSION

*Properly installed and maintained, wood duck boxes help supplement numbers of natural cavities and may increase local populations of wood ducks. Predator guards are essential to exclude raccoons and snakes.*

## PLACEMENT

Boxes should be filled with at least 2 inches of wood shavings and fastened to either a 4-inch x 4-inch treated post or smooth pipe. Post length will vary depending on soil type; 16-foot posts may be needed, however, when installing boxes in bogs or swamps. When finished, boxes should be a minimum of 5 feet above the water or ground. (Remember to account for settling of posts in soft muck after several years). Place boxes higher when considerable fluctuations in water levels are expected. Boxes should be attached with either no tilt or a slight forward tilt. Boxes tilted backwards prevent ducklings from climbing the wall and leaving the nest. Boxes should be erected by January to maximize chances that they will be used the first nesting season. It sometimes takes a few years for boxes to be used. Guidelines for the location of boxes are as follows:

1. Place boxes near brood habitat. Preferred brood rearing areas are characterized by still or slow-moving water sheltered by the wind with vegetation overhanging the water's edge.
2. Place boxes over water or on land adjacent to water. If placed on land, boxes should be as close as possible to permanent water to reduce predation of young ducklings when they travel to and from brood habitat.
3. Place one box per post.
4. Place boxes 100 to 200 yards apart and where they will be visually isolated from each other.
5. Trim away overhanging limbs and branches as predators may use these to gain entrance into the box.
6. Keep entrance holes clear of obstructions, regardless of box placement. Wood ducks fly directly into boxes and do not need a perch.

Recent research indicates that in areas where boxes are clumped, dump nesting occurs (see the Biology and Life History section of this booklet on page 6). In areas with intensive nest box programs, dump nesting leads to an increase in nest abandonment and may lead to an overall decline in productivity. Problems with dump nesting usually do not occur until several years after an intensive nest box program is initiated. Generally, fewer well-scattered boxes produce as many ducklings as highly clumped boxes and require less time for annual maintenance and repair.

#### MAINTENANCE

Boxes must be checked each year at which time unhatched eggs, shell membranes or nesting material from other birds or squirrels should be removed and replaced with fresh wood shavings. Checks should be made in late fall or winter, but prior to January, so as not to interfere with nesting. Repairs to boxes and removal of obstructions from entrance holes should also be made at this time.



DENNIS LUSZCS

*The presence of thin, papery shell membranes are an indication that ducklings have hatched and the nest was successful.*

# Let's Build A Wood Duck Box

The lack of suitable natural cavities is thought to be one of the most important factors that limit the continued growth of wood duck populations. You can help by constructing and placing wood duck boxes in suitable habitat where natural tree cavities may not exist.

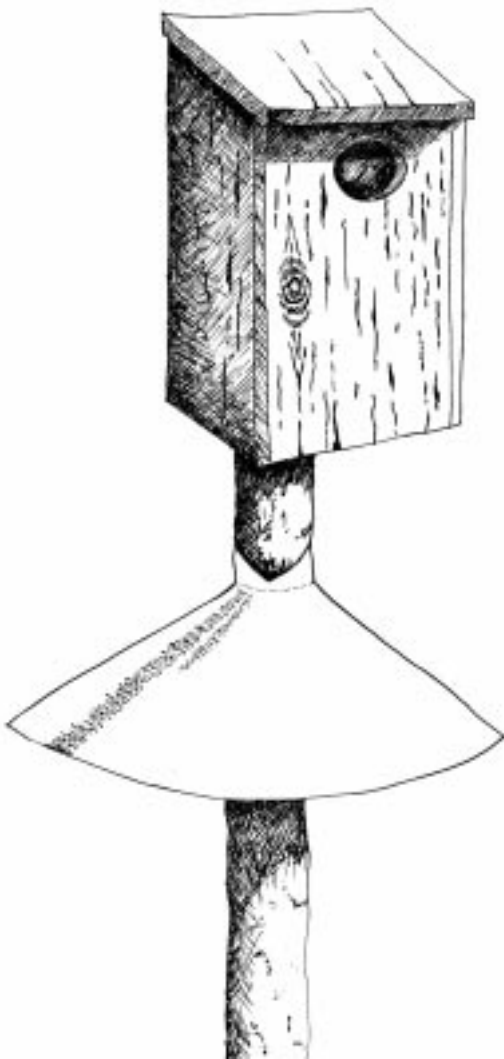

## Materials

- Wood:** 10 linear feet of 1-inch x 12-inch rough-cut cedar or cypress lumber
- Nails:** 25 size 8-or 10-penny zinc-coated
- One lag bolt:** 4 inches or longer
- Hinge:** 1, with 3-inch cabinet screws
- Hardware cloth:** 18-inch strip at least 3 inches wide (sharp ends bent under)
- One post:** 4-inch x 4-inch, up to 16 feet long (should be cypress, cedar or treated wood)
- Wood shavings or chips:** enough to form a 3-inch nest base in each box

## When

Wood duck pair formation begins as early as October, and the ducks begin searching for nest sites in winter. Therefore you should install boxes by the end of December. Nesting begins in early spring and peaks in North Carolina in April and May but continues through July.

## Where

Boxes may be placed in ponds, impoundments, beaver ponds, swamps or secluded coves on larger lakes. To prevent dump nesting, place wood duck boxes at least 100 to 200 yards apart, with boxes visually isolated from each other. Always place boxes near good brood habitat to maximize hatchling survival. Boxes should be placed at least 5 feet above water level and tilted slightly forward to allow hatchlings to crawl up the wall and escape. Never tilt boxes backward as this can prevent their escape.

## Brood Habitat

Good brood habitat consists of shallow, slow-moving or still water with plenty of nearby emergent aquatic vegetation and overhanging cover from trees or bushes near the water. This will provide protection, particularly from avian predators. Water should be present from February through July.

**Lumber layout:**  
10 linear feet  
of 1' x 12"  
rough lumber

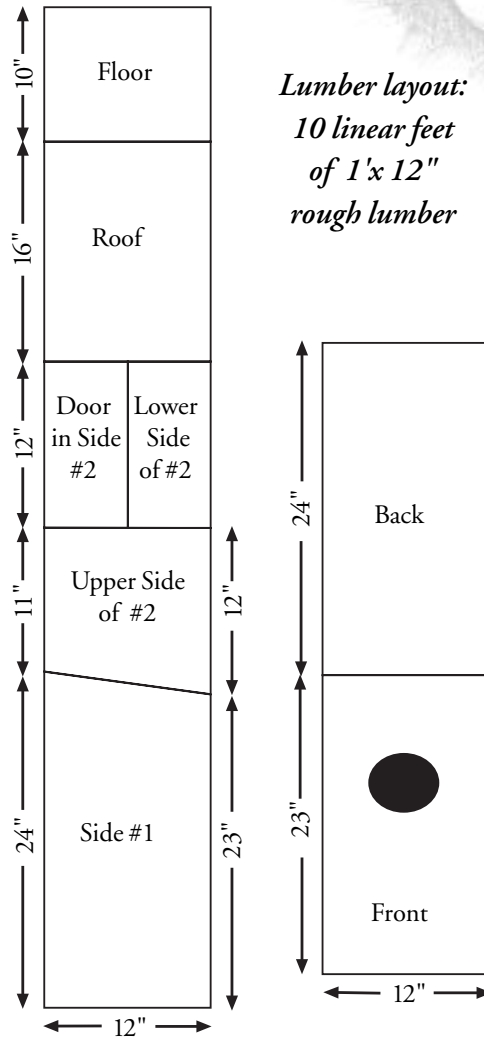

## Components layout

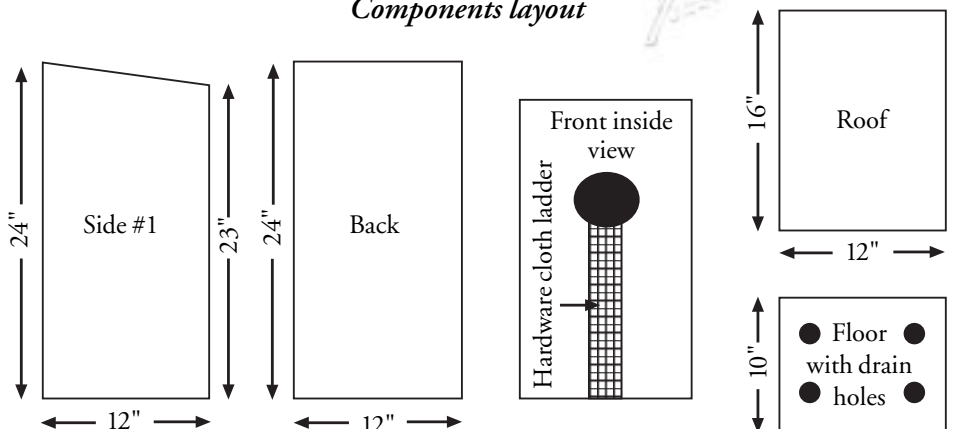

## Assembly of standard wood duck box

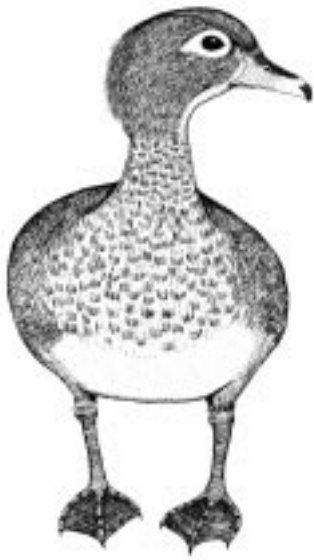

### PREDATOR GUARDS

Pictured is a layout for cutting three predator guards from a 3-foot x 8-foot sheet of 26-gauge galvanized metal. To facilitate cutting (on solid lines only), follow the sequence of numbers. Make circular cuts in a counter-clockwise direction. To make initial cuts on line A-B, make a slot at A with a cold chisel. Use tin snips and wear leather gloves. After cutting, fold guards over to the slashed line,

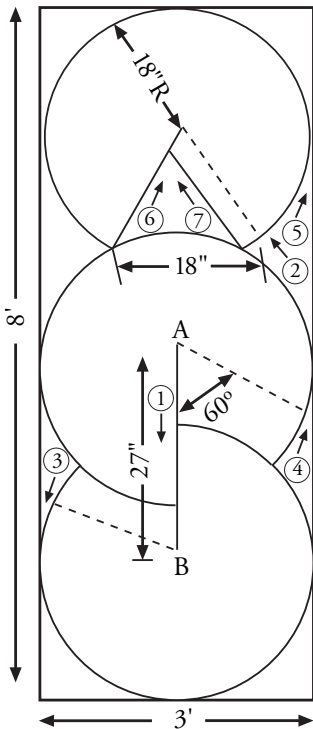

forming a cone, and fasten with three sheet metal screws. Make an X-shaped cut in the center of each guard. The sheet metal can then be folded back to form four flaps. This allows for an approximate square opening for the post to slide through. Attach the guard to the post with 1-inch roofing nails or screws. Many heating and air conditioning contractors can cut these guards cheaply.

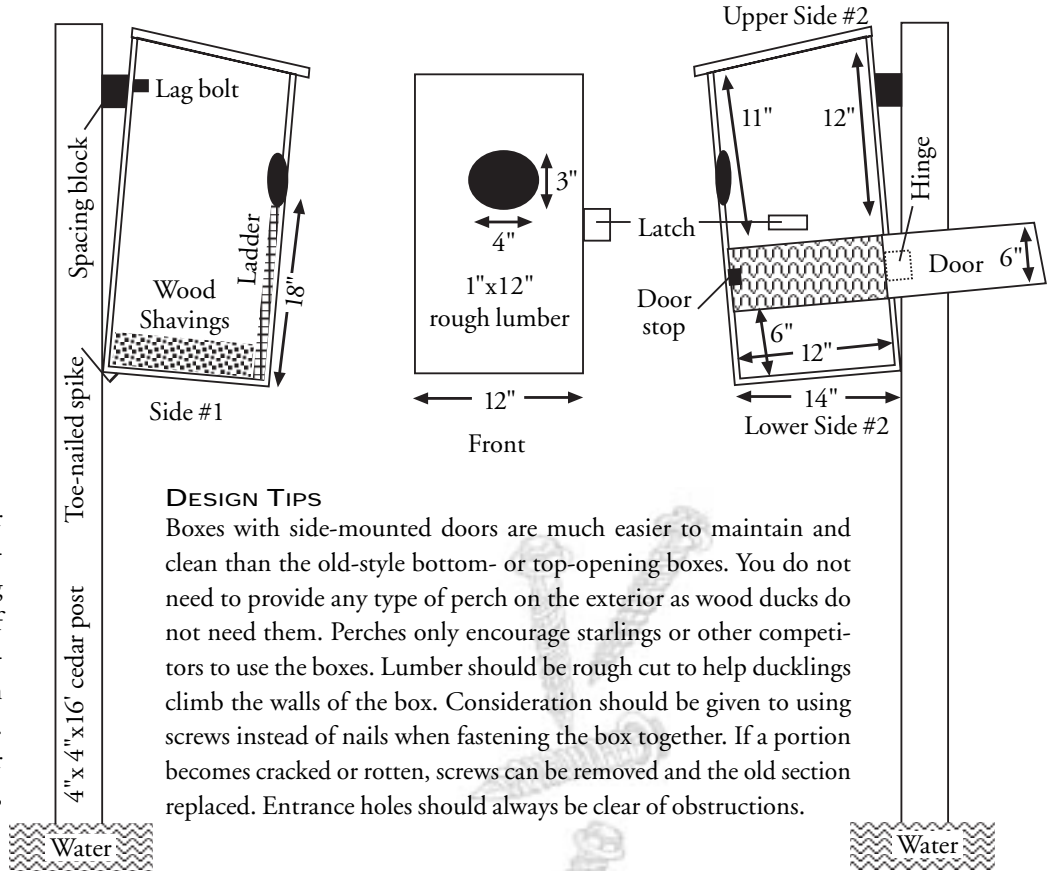

### DESIGN TIPS

Boxes with side-mounted doors are much easier to maintain and clean than the old-style bottom- or top-opening boxes. You do not need to provide any type of perch on the exterior as wood ducks do not need them. Perches only encourage starlings or other competitors to use the boxes. Lumber should be rough cut to help ducklings climb the walls of the box. Consideration should be given to using screws instead of nails when fastening the box together. If a portion becomes cracked or rotten, screws can be removed and the old section replaced. Entrance holes should always be clear of obstructions.

### PREDATORS AND COMPETITORS

Raccoons are the most serious predators of nesting wood ducks, and unprotected boxes can become death traps for both the adult hen and her brood. The use of cone-shaped predator guards is absolutely essential if you want your boxes to do more good than harm. Never put a wood duck box up without predator guards.

Starlings are serious competitors for nest space in boxes. Because they are an unprotected, nonnative species, their nests should be removed from boxes promptly, and adult starlings should be dispatched when encountered. Hatchling mortality from avian predators can be high but may be minimized by placing boxes near good brood habitat. Turtles commonly eat hatchlings and can be trapped and removed from smaller ponds if they are a problem. Black rat snakes are also egg eaters and able climbers, but cone-shaped guards deter almost all predation from snakes.

### MAINTENANCE

Research has shown that box use is much higher and nesting more successful if boxes receive annual maintenance. Each fall or early winter you should clean out old nests, removing old nesting material, eggs and membranes, parasites and wasp or bee nests. Fresh cedar or cypress shavings should be added and any repairs made before the new nesting season begins.



ILLUSTRATED BY KIMBERLY K.C. SCHOTT

Wood ducks provide hunting enjoyment to thousands of North Carolina waterfowl hunters statewide. Annually, wood ducks make up the highest harvest totals in North Carolina and may comprise nearly 50 percent of the total harvest in some years (Figure 4). Numbers of wood ducks harvested vary from year to year based on several factors including fall population, hunter interest, weather, and season length and bag limits. North Carolina wood duck harvests have approached nearly 100,000 during years with liberal bag limits or season length (Figure 5). While many factors influence the distribution of the wood duck harvest in North Carolina, highest wood duck harvests (by county) are reported in the southeast Coastal Plain and those counties bordering the Roanoke River in northeast North Carolina (Figure 6).

Wood ducks also provide many recreational opportunities for persons interested in observing and photographing wildlife and waterfowl and learning more about their habits and behaviors. Interest in nest box programs continues to increase. These programs provide many hours of enjoyment. Wood ducks can be observed in many state parks, state game lands and federal wildlife refuges. A nearby, secluded farm pond or beaver pond, however, usually provides the best viewing opportunities.



EUGENE HESTER

*Proper habitat and harvest management will help ensure that wood ducks continue to provide recreational enjoyment for all.*

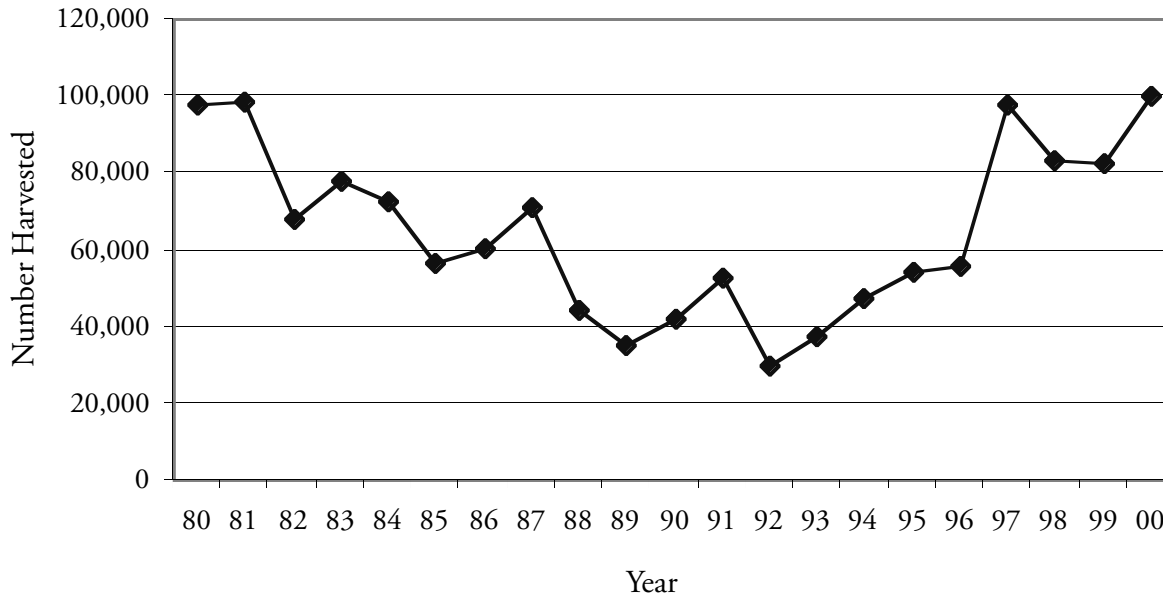
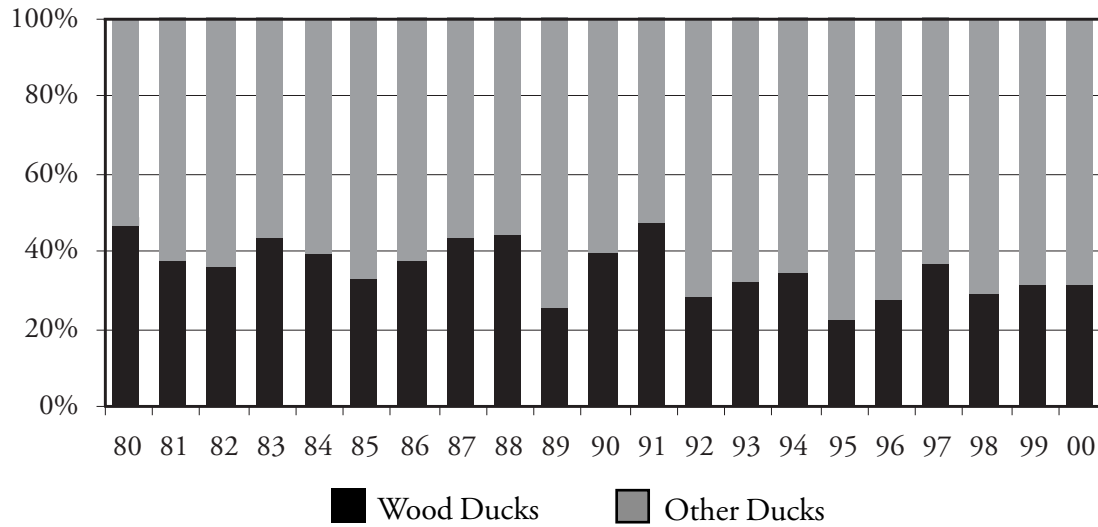

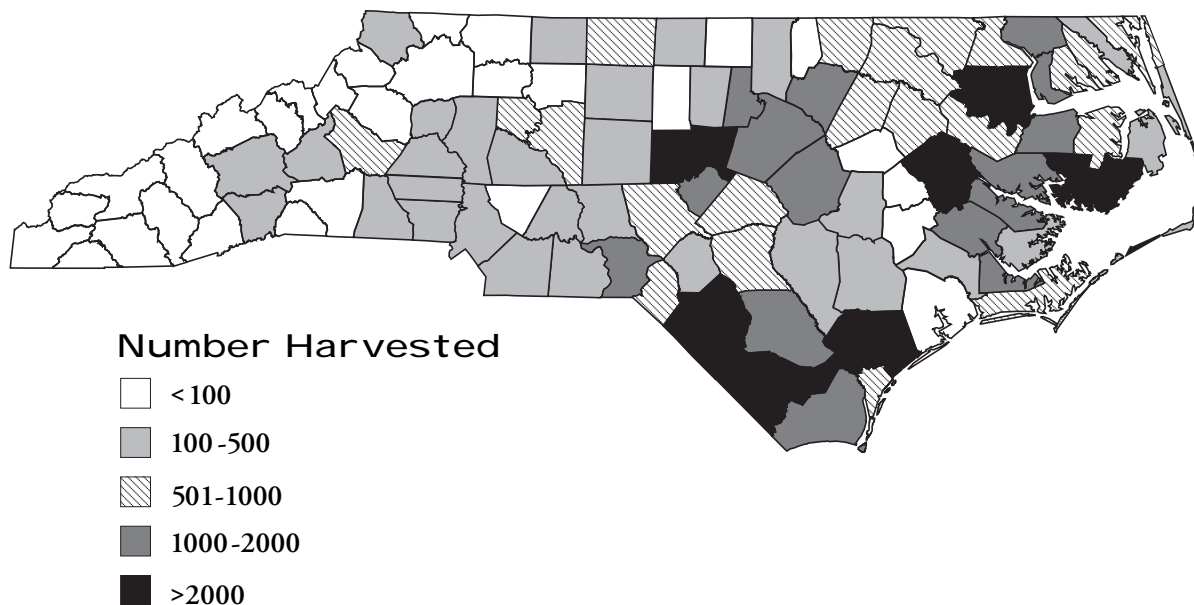

**FIGURE 6**  
Average annual wood duck harvest in North Carolina, 1991-2000

Year	Season Length	Daily Bag Limit
1980-81	50 days	5 early season 2 remaining season
1981-82	50 days	5 early season 2 remaining season
1982-83	50 days	5 early season 2 remaining season
1983-84	50 days	5 early season 2 remaining season
1984-85	50 days	5 early season 2 remaining season
1985-86	40 days	4 early season 2 remaining season
1986-87	40 days	4 early season 2 remaining season
1987-88	40 days	4 early season 2 remaining season
1988-89	30 days	3 early season 2 remaining season
1989-90	30 days	2
1990-91	30 days	2
1991-92	30 days	2
1992-93	30 days	2
1993-94	30 days	2
1994-95	40 days	2
1995-96	50 days	2
1996-97	50 days	2
1997-98	60 days	2
1998-99	60 days	2
1999-00	60 days	2
2000-01	60 days	2

**TABLE 2**  
North Carolina waterfowl season lengths and daily wood duck bag limits, 1980 - 2000.

## REFERENCES

- Beshears, W.W. Jr. 1974. *Wood Ducks in Alabama*. Alabama Department of Conservation and Natural Resources, Montgomery, AL. 45pp.
- Bellrose, F.C. 1980. *Ducks, Geese and Swans of North America, 3rd ed.* Stackpole Books, Harrisburg, PA. 540pp.
- Bellrose, F.C. and D. J. Holm. 1994. *Ecology and Management of the Wood Duck*. Stackpole Books, Mechanicsburg, PA. 588pp.
- Cooperative Extension Service – Clemson University. 1994. *The Clemson Beaver Pond Leveler*. AFW Leaflet 1.
- Fredrickson, L.H., G.V. Burger, S.P. Havera, D.A. Graber, R.E. Kirby and T.S. Taylor (Eds.). 1990. *Proceedings of the 1988 North American Wood Duck Symposium*, St. Louis, MO. 390pp.
- Owen, W., P.W. Sumner, G.S. Warburton and R.C. Wilson. 1987. *Beaver Management in North Carolina*. North Carolina Wildlife Resources Commission, Raleigh, NC. 16pp.

WILDLIFE RESOURCES COMMISSION  
PUBLICATIONS

The Division of Wildlife Management has several other publications about wildlife and their habitats that are available to the public. They can be obtained by contacting the division at the following address: Division of Wildlife Management, N.C. Wildlife Resources Commission, 1722 Mail Service Center, Raleigh, NC 27699-1722. These publications are also available online through the N.C. Wildlife Resources Commission's Web site at [www.ncwildlife.org](http://www.ncwildlife.org).

Tarheel Wildlife On the Farm  
White-Tailed Deer in North Carolina  
The Wild Turkey in North Carolina  
The Wild Boar in North Carolina  
Beaver Management in North Carolina  
An Evaluation of Deer Management Options

You can order other publications and products created by the Wildlife Resources Commission through the N.C. WILD Store catalog. The catalog is published in *Wildlife in North Carolina* magazine, or you can view it online at [www.ncwildlife.org](http://www.ncwildlife.org). The magazine and other products can be ordered by phone as well at (919) 662-4377.

Written by Joseph C. Fuller, Division of Wildlife Management  
Produced by the North Carolina Wildlife Resources Commission  
1701 Mail Service Center, Raleigh, NC 27699-1701  
Cover photograph by E. Eugene Hester

Report Wildlife  
Violations.  
Call  
1-800-662-7137



The Wildlife Resources Commission is an Equal Opportunity Employer. All wildlife programs are administered for the benefit of all North Carolina citizens without prejudice towards age, sex, race, religion or national origin. Violations of this pledge may be reported to the Equal Employment Officer: Carol Batker, Personnel Officer, N.C. Wildlife Resources Commission, 1701 Mail Service Center, Raleigh, NC 27699-1701, (919) 733-2241.